

# CruX Mathematicorum

Volume 17 , Number 2

February 1991

## CONTENTS

The Olympiad Corner: No. 122 .....	R.E. Woodrow	33
Book Review .....		42
Call For Papers—ICME .....		42
Problems: 1611–1620 .....		43
Solutions: 1390, 1430, 1486, 1492–1501, 1503 .....		45
Jack Garfunkel .....		64

## THE OLYMPIAD CORNER

No. 122

R.E. WOODROW

*All communications about this column should be sent to Professor R.E. Woodrow, Department of Mathematics and Statistics, The University of Calgary, Calgary, Alberta, Canada, T2N 1N4.*

It has been some time since we published a problem set from France, and in this issue we give the problems of the 1988 sitting of the French national competition. Thanks to Bruce Shawyer, Memorial University of Newfoundland, for sending them in.

### COMPOSITION DE MATHÉMATIQUES

Session de 1988

Time: 5 hours

**Problem I.** Let  $N$ ,  $p$ ,  $n$  be non-zero whole numbers. Consider a rectangular matrix  $T$  having  $n$  lines numbered 1 through  $n$ , and  $p$  columns numbered 1 through  $p$ . For  $1 \leq i \leq n$  and  $1 \leq k \leq p$ , the entry in row  $i$  and column  $k$  is an integer  $a_{ik}$  satisfying  $1 \leq a_{ik} \leq N$ . Let  $E_i$  be the set of integers appearing in row  $i$ .

Answer Question 1 or 2.

*Question 1.*

In this question two further conditions are imposed on  $T$ :

- i. for  $1 \leq i \leq n$ ,  $E_i$  has exactly  $p$  elements;
- ii. for different values of  $i$  and  $j$ , the sets  $E_i$  and  $E_j$  are different.

Let  $m$  be the smallest value of  $N$  for which, given values for  $n$  and  $p$ , one can form a matrix  $T$  having the preceding properties.

- (a) Calculate  $m$  for  $n = p + 1$ .
- (b) Calculate  $m$  for  $n = 10^{30}$  and  $p = 1988$ .
- (c) Determine the limit of  $m^p/n$  where  $p$  is fixed and  $n$  tends to infinity.

*Question 2.*

In this question we replace the two extra conditions of Question 1 by the two following conditions:

- i.  $p = n$ ;
- ii. for every ordered pair of positive integers  $(i, k)$  with  $i + k \leq n$ , the integer  $a_{ik}$  does not belong to the set  $E_{i+k}$ .

- (a) Show that for distinct  $i$  and  $j$  the sets  $E_i$  and  $E_j$  are different.
- (b) Show that if  $n$  is at least  $2^q$ , where  $q$  is a positive integer, then  $N \geq q + 1$ .
- (c) Suppose that  $n = 2^r - 1$ , where  $r$  is a fixed positive integer. Show that  $N \geq r$ .

**Exercise II.** Determine, for  $n$  a positive integer, the sign of  $n^6 + 5n^5 \sin n + 1$ . For which positive integers  $n$  is it true that

$$\frac{n^2 + 5n \cos n + 1}{n^6 + 5n^5 \sin n + 1} \geq 10^{-4}?$$

**Exercise III.** Consider two spheres  $\Sigma_1$  and  $\Sigma_2$  and a straight line  $\Delta$  which does not meet them. For  $i = 1$  and  $i = 2$ , let  $C_i$  be the centre of  $\Sigma_i$ ,  $H_i$  the orthogonal projection of  $C_i$  on  $\Delta$ ,  $r_i$  the radius of  $\Sigma_i$ , and let  $d_i$  be the distance of  $C_i$  to  $\Delta$ . Let  $M$  be a point on  $\Delta$ , and for  $i = 1$  and  $i = 2$ , let  $T_i$  be the point of contact with  $\Sigma_i$  of a plane tangent to  $\Sigma_i$  and passing through  $M$ ; set  $\delta_i(M) = MT_i$ . Situate  $M$  on  $\Delta$  so that  $\delta_1(M) + \delta_2(M)$  is minimized.

**Exercise IV.** Consider five points  $M_1, M_2, M_3, M_4, M$  situated on a circle  $C$  in the plane. Show that the product of the distances of  $M$  from the lines  $M_1M_2$  and  $M_3M_4$  equals the product of the distances from  $M$  to the lines  $M_1M_3$  and  $M_2M_4$ . What can one deduce about  $2n + 1$  distinct points  $M_1, \dots, M_{2n}, M$  situated on  $C$ ?

\*                    \*                    \*

Now we turn to solutions sent in response to the appeal to help “tidy up” the archives.

**K797.** [1983: 270] *Problems from Kvant*.

It is well known that the last digit of the square of an integer is one of the following: 0,1,4,5,6,9. Is it true that any finite sequence of digits may appear before the last one, that is, for any sequence of  $n$  digits  $\{a_1, a_2, \dots, a_n\}$  there exists an integer whose square ends with the digits  $a_1a_2 \dots a_nb$ , where  $b$  is one of the digits listed above?

*Solutions by Andy Liu, University of Alberta and by Richard K. Guy, University of Calgary.*

The answer is no. The sequence of digits 101 cannot precede the units digit in any square. Suppose on the contrary that there exist integers  $k$  and  $y$ , and a digit  $x$  in  $\{0, 1, \dots, 9\}$ , such that  $k^2 = 10^4y + 1010 + x$ . We know that  $k^2 \equiv 0$  or  $1 \pmod{4}$ . Now  $10^4y + 1010 + x \equiv 2 + x \pmod{4}$ . Hence  $x = 2, 3, 6$  or  $7$ . However,  $k^2$  cannot end in 2, 3, or 7. Hence  $k^2 = 10^4y + 1016$ . We must have  $k = 2h$  for some integer  $h$ , and then  $h^2 = 2500y + 254 \equiv 2 \pmod{4}$ , a contradiction.

Alternatively, consider any sequence of the form  $40k + 39$ . Squares cannot end as  $\dots 90, \dots 91, \dots 94, \dots 95$  or  $\dots 99$ , and  $400k + 396 = (10x \pm 4)^2$  gives  $20k + 19 = 5x^2 \pm 4x$ , which implies that  $x$  is odd and  $19 \equiv 5 \pmod{4}$ , a contradiction.

\*

Turning now to the 1985 problems from the Corner, I would like to thank Murray Klamkin who sent in a large number of solutions as well as references to some solutions which have appeared in his book *International Mathematical Olympiads 1979–1985*, MAA, Washington, D.C., 1986. Here is a listing of those problems from the 1985 numbers for which solutions are discussed in his book.

p.38/#16	Listed as G.I./5	on pp. 13, 88-91.
p.38/#21	Listed as S.G./2	on pp. 12, 82.
p.72/#40	Listed as G.I./1	on pp. 12, 83-84.
p.72/#41	Listed as P.G./4	on pp. 12, 80-81.

p.72/#42	Listed as N.T./5	on pp. 11, 76–77.
p.73/#44	Listed as A/1	on pp. 9, 61–63.
p.73/#45	Listed as A/5	on pp. 10, 67–68.
p.103/#58	Listed as A/9	on pp. 10, 72–73.
p.104/#62	Listed as C/1	on pp. 14, 99–100.
p.104/#65	Listed as A/10	on pp. 10, 73–75.
p.105/#69	Listed as A/8	on pp. 10, 71–72.
p.105/#70	Listed as A/6	on pp. 10, 68–70.
p.305/#7	Listed as P.G./3	on pp. 12, 79–80.
p.305/#12	Listed as G.I./6	on pp. 13, 91.
p.306/#16	Listed as I/2	on pp. 13, 96–97.

\*

The next block of solutions are for problems from the unused IMO proposals given in the 1985 numbers of *CruX*.

**17.** [1985: 38] *Proposed by Poland.*

Given nonnegative real numbers  $x_1, x_2, \dots, x_k$  and positive integers  $k, m, n$  such that  $km \leq n$ , prove that

$$n \left( \prod_{i=1}^k x_i^m - 1 \right) \leq m \sum_{i=1}^k (x_i^n - 1).$$

*Solution by Murray S. Klamkin, University of Alberta.*

Let  $P = x_1 x_2 \cdots x_k$ . Since  $\sum_{i=1}^k x_i^n \geq kP^{n/k}$ , it suffices to show that

$$nP^m - n \leq mkP^{n/k} - mk$$

or that

$$\frac{P^m - 1}{m} \leq \frac{P^r - 1}{r} \tag{1}$$

where  $r = n/k \geq m$ . (1) follows from the known result that  $(P^x - 1)/x$  is increasing in  $x$  for  $x \geq 0$ . A proof follows immediately from the integral representation

$$\frac{P^x - 1}{x \ln P} = \int_0^1 e^{xt \ln P} dt.$$

Finally it is to be noted that  $m$  and  $n$  need not be positive integers, just being positive reals with  $n \geq km$  suffices.

**23.** [1985: 39] *Proposed by the USSR.*

A tetrahedron is inscribed in a unit sphere. The tetrahedron is such that the center of the sphere lies in its interior. Show that the sum of the edge lengths of the tetrahedron exceeds 6.

*Comment by Murray S. Klamkin, University of Alberta.*

It is shown more generally in [1] that “The total edge length of a simplex inscribed in a unit sphere in  $E^n$  with the center in the interior is greater than  $2n$ ”. Also, still more general results are given.

*Reference:*

[1] G. D. Chakerian and M. S. Klamkin, Inequalities for sums of distances, *Amer. Math. Monthly* **80** (1973) 1009–1017.

**25.** [1985: 39] *Proposed by the USSR.*

A triangle  $T_1$  is constructed with the medians of a right triangle  $T$ . If  $R_1$  and  $R$  are the circumradii of  $T_1$  and  $T$ , respectively, prove that  $R_1 > 5R/6$ .

*Solution by Murray S. Klamkin, University of Alberta.*

The inequality should be  $R_1 \geq 5R/6$  since equality occurs for an isosceles right triangle. If  $a, b, c$  are the sides of  $T$  with  $c^2 = a^2 + b^2$ , then

$$4m_a^2 = 4b^2 + a^2, \quad 4m_b^2 = 4a^2 + b^2, \quad 4m_c^2 = a^2 + b^2,$$

where  $m_a, m_b, m_c$  are the medians corresponding to  $a, b, c$  respectively. Also,

$$R_1 = \frac{m_a m_b m_c}{4F_1} = \frac{m_a m_b m_c}{3F}$$

where  $F = ab/2$  is the area of  $T$ ,  $F_1$  the area of  $T_1$ . Also  $R = c/2$ . The given inequality now becomes  $8m_a m_b m_c \geq 5abc$  or, squaring,

$$(a^2 + b^2)(a^2 + 4b^2)(4a^2 + b^2) = 64(m_a m_b m_c)^2 \geq 25a^2 b^2 c^2 = 25a^2 b^2 (a^2 + b^2).$$

Expanding out and factoring, we obtain the obvious inequality

$$(a^2 + b^2)(a^2 - b^2)^2 \geq 0.$$

There is equality if and only if  $a = b$ .

**48.** [1985: 73] *Proposed by the USSR.*

Let  $O$  be the center of the axis of a right circular cylinder; let  $A$  and  $B$  be diametrically opposite points in the boundary of its upper base; and let  $C$  be a boundary point of its lower base which does not lie in the plane  $OAB$ . Show that

$$\angle BOC + \angle COA + \angle AOB = 2\pi.$$

*Correction and solution by Murray S. Klamkin, University of Alberta.*

The inequality should read  $\angle BOC + \angle COA + \angle AOB \leq 2\pi$ , and is immediate by the known result that the sum of the face angles of a convex polyhedral angle is less than  $2\pi$ . See, e.g., p. 61 of my book *USA Mathematical Olympiads 1972–1986*, MAA, 1988.

\*

The last seven solutions are to problems from other Olympiads which appeared in the 1985 issues.

**2.** [1985: 168] *1984 Dutch Olympiad.*

In the given diagram,  $B$  is a battery,  $L$  is a lamp, and  $S_1, S_2, S_3, S_4, S_5$  are switches. The probability that switch  $S_3$  is on is  $2/3$ , and it is  $1/2$  for the other four switches. These probabilities are independent. Compute the probability that the lamp is on.

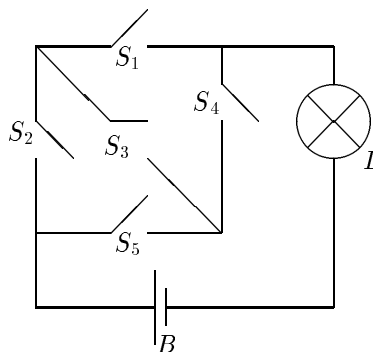

*Solution by Murray S. Klamkin, University of Alberta.*

More generally, let  $p_i$  and  $q_i$  denote switch  $S_i$  being on or off, respectively, and also their probabilities so  $0 \leq p_i, q_i \leq 1$ ,  $p_i + q_i = 1$ . The probability that the lamp is on is given by

$$p_1 p_2 p_3 p_4 p_5 + \sum q_1 p_2 p_3 p_4 p_5 + \sum q_1 q_2 p_3 p_4 p_5 - q_2 q_5 p_1 p_3 p_4 - q_1 q_4 p_2 p_3 p_5 \\ + p_1 p_2 q_3 q_4 q_5 + p_4 p_5 q_1 q_2 q_3.$$

The sums are symmetric over the  $p$ 's and  $q$ 's. Note that if at most one switch is off, the lamp is on; if any two switches except  $q_2 q_5$  or  $q_1 q_4$  are off, the lamp is on, and finally if only two switches are on they must be  $p_1 p_2$  or  $p_4 p_5$ . [*Editor's note:* this gives a probability of  $25/48$  for the above problem.]

\*

**4.** [1985: 237] *1981 Leningrad High School Olympiad.*

A plane is partitioned into an infinite set of unit squares by parallel lines. A triangle  $ABC$  is constructed with vertices at line intersections. Show that if  $|AB| > |AC|$ , then  $|AB| - |AC| > 1/p$ , where  $p$  is the perimeter of the triangle. (Grades 8, 9, 10)

*Solution by Murray S. Klamkin, University of Alberta.*

Without loss of generality we can take the rectangular coordinates of  $A, B, C$  to be  $(0, 0), (x, y), (u, v)$ , respectively, where  $x, y, u, v$  are integers. Then letting  $c^2 = |AB|^2 = x^2 + y^2$ ,  $b^2 = |AC|^2 = u^2 + v^2$ ,  $a^2 = |BC|^2 = (x - u)^2 + (y - v)^2$ , we have to show that

$$(c - b)(c + b + a) = c^2 - b^2 + (c - b)a > 1.$$

Finally, since  $c^2 - b^2$  is a positive integer it is  $\geq 1$ ; also  $(c - b)a > 0$ .

**6.** [1985: 237] *1981 Leningrad High School Olympiad.*

In a convex quadrilateral the sum of the distances from any point within the quadrilateral to the four straight lines along which the sides lie is constant. Show that the quadrilateral is a parallelogram. (Grade 9)

*Solution by Murray S. Klamkin, University of Alberta.*

Assume for the quadrilateral  $ABCD$  that lines  $AD$  and  $BC$  are not parallel; so they must meet in a point  $E$  as in the figure. Now draw a chord  $c = GH$  of  $ABCD$  perpendicular to the angle bisector of angle  $E$ . It follows by considering the area of the isosceles triangle  $EGH$  that the sum of the distances from any point on  $c$  to lines  $AD$  and  $BC$  is constant. Consequently, by hypothesis, the sum of the distances from any point of  $c$  to lines  $AB$  and  $CD$  is constant. If  $AB$  and  $CD$  are not parallel, let their point of intersection be  $F$  and draw 2 chords  $f$  and  $f'$  of  $ABCD$  perpendicular to the angle bisector of angle  $F$ , with  $f$  nearer to  $F$ . It follows easily that the sum of the perpendiculars to lines  $AB$  and  $CD$  from a point on  $f$  is less than from a point on  $f'$ . Consequently,  $AB$  must be parallel to  $CD$ . Proceeding in a similar way using another chord  $c'$  parallel to  $c$ , it follows also that  $AD$  must be parallel to  $BC$ , whence the figure must be a parallelogram.

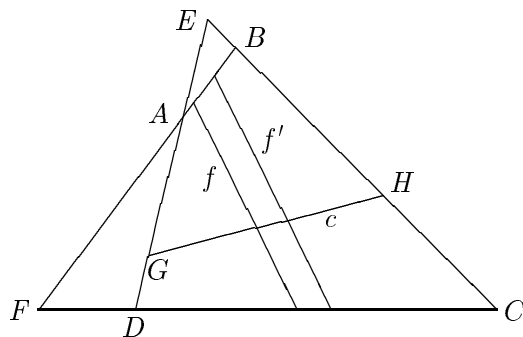

It is to be noted that a non-convex quadrilateral cannot have the given property. Also as a rider, show that if the sum of the six distances from any point within a hexahedron is constant, the hexahedron must be a parallelepiped.

\*

**5.** [1985: 239] *1984 Bulgarian Mathematical Olympiad.*

Let  $0 \leq x_i \leq 1$  and  $x_i + y_i = 1$ , for  $i = 1, 2, \dots, n$ . Prove that

$$(1 - x_1 x_2 \cdots x_n)^m + (1 - y_1^m)(1 - y_2^m) \cdots (1 - y_n^m) \geq 1$$

for all positive integers  $m$  and  $n$ .

*Comment by Murray S. Klamkin, University of Alberta.*

In my editorial note to Problem 68-1 (*SIAM Review* 11(1969) 402-406), I gave the more general inequality

$$\prod_{i=1}^n \left(1 - \prod_{j=1}^m p_{ij}\right) + \prod_{j=1}^m \left(1 - \prod_{i=1}^n q_{ij}\right) > 1 \quad (1)$$

where  $p_{ij} + q_{ij} = 1$ ,  $0 < p_{ij} < 1$ , and  $m, n$  are positive integers greater than 1. (The cases  $m, n = 1$  are trivial.) Just let  $p_{ij} = x_j$  for all  $i$  and interchange  $m$  and  $n$  to get the given inequality. Other particularly nice special cases of the above inequality are

$$\left(1 - \frac{1}{2^n}\right)^m + \left(1 - \frac{1}{2^m}\right)^n > 1$$

and

$$\frac{1}{2^m} + \frac{1}{2^{1/m}} < 1.$$

Further extensions of (1) have been given by Joel Brenner.

\*

2. [1985: 239] 1983 Annual Greek High School Competition.

If  $\mathbf{a}$  and  $\mathbf{b}$  are given nonparallel vectors, solve for  $x$  in the equation

$$\frac{\mathbf{a}^2 + x\mathbf{a} \cdot \mathbf{b}}{|\mathbf{a}||\mathbf{a} + x\mathbf{b}|} = \frac{\mathbf{b}^2 + \mathbf{a} \cdot \mathbf{b}}{|\mathbf{b}||\mathbf{a} + \mathbf{b}|}.$$

*Solution by Murray S. Klamkin, University of Alberta.*

One can solve by squaring out and solving the rather messy quadratic in  $x$ . However, it is easier to proceed geometrically. Referring to the figure, the given equation requires that  $\angle SPQ = \angle PRQ$  ( $= \phi$ , say). Thus  $\triangle PQS \sim \triangle RQP$ .

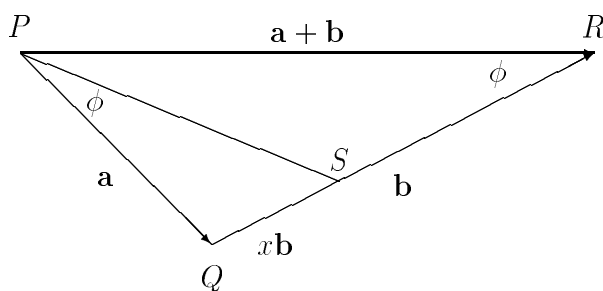

Thus, putting  $a = |\mathbf{a}|$  and  $b = |\mathbf{b}|$ ,  $xb/a = a/b$  or  $x = a^2/b^2$ .

Also,  $x = -x'$  can be negative as in the following figure.

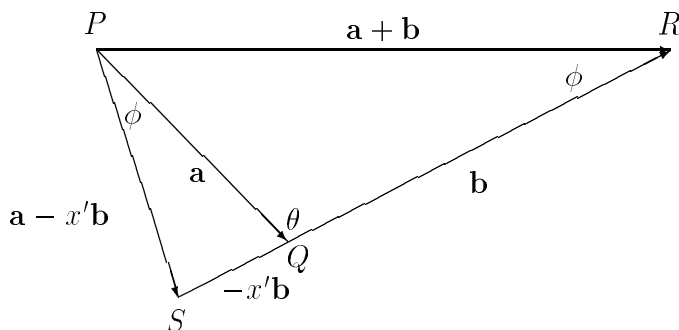

By the law of sines,  $a/\sin(\theta - \phi) = x'b/\sin \phi$ , and  $a/\sin \phi = b/\sin(\theta + \phi)$ . Hence,

$$\sin(\theta + \phi) - \sin(\theta - \phi) = \frac{b \sin \phi}{a} - \frac{a \sin \phi}{x'b}$$

or  $2 \cos \theta = b/a - a/x'b$ . Finally,

$$x = -x' = \frac{-a^2}{b(b - 2a \cos \theta)} = \frac{-a^2}{b^2 + 2\mathbf{a} \cdot \mathbf{b}}.$$

\*

**3.** [1985: 304] *Proposed by Canada.*

Determine the maximum value of

$$\sin^2 \theta_1 + \sin^2 \theta_2 + \cdots + \sin^2 \theta_n,$$

where  $\theta_1 + \theta_2 + \cdots + \theta_n = \pi$  and all  $\theta_i \geq 0$ .

*Solution by Edward T.H. Wang, Wilfrid Laurier University, Waterloo, Ontario.*

Let  $f(n)$  denote the maximum value. Then obviously  $f(1) = 0$  and  $f(2) = 2$ , the latter attained if and only if  $\theta_1 = \theta_2 = \pi/2$ . When  $n = 3$ , it is well known that

$$\sin^2 \theta_1 + \sin^2 \theta_2 + \sin^2 \theta_3 \leq \frac{9}{4}$$

with equality just when  $\theta_1 = \theta_2 = \theta_3 = \pi/3$ . (See O. Bottema et al, *Geometric Inequalities*, item 2.3 on p. 18 or the equivalent inequality in item 2.23 on p. 25.) Thus  $f(3) = 9/4$ . We show that  $f(n) = 9/4$  for all  $n \geq 3$  by proving the following theorem.

**Theorem:** Let  $\theta_i \geq 0$  for all  $i = 1, 2, \dots, n$  be such that  $\sum_{i=1}^n \theta_i = \pi$  with  $n \geq 3$ . Then  $\sin^2 \theta_1 + \sin^2 \theta_2 + \cdots + \sin^2 \theta_n \leq 9/4$  with equality holding if and only if  $\theta_1 = \theta_2 = \theta_3 = \pi/3$  and  $\theta_i = 0$  for all  $i = 4, 5, \dots, n$ , where we have, without loss of generality, renumbered the indices so that  $\theta_1 \geq \theta_2 \geq \theta_3 \geq \cdots \geq \theta_n$ .

We first give a simple lemma.

**Lemma:** If  $A \geq 0$  and  $B \geq 0$  are such that  $A+B \leq \pi/2$ , then  $\sin^2 A + \sin^2 B \leq \sin^2(A+B)$  with equality if and only if  $A = 0$  or  $B = 0$  or  $A + B = \pi/2$ .

*Proof:*  $\sin^2(A+B) - (\sin^2 A + \sin^2 B)$

$$\begin{aligned} &= \sin^2 A \cos^2 B + 2 \sin A \sin B \cos A \cos B + \cos^2 A \sin^2 B - \sin^2 A - \sin^2 B \\ &= 2 \sin A \sin B \cos A \cos B - \sin^2 A (1 - \cos^2 B) - \sin^2 B (1 - \cos^2 A) \\ &= 2 \sin A \sin B (\cos A \cos B - \sin A \sin B) \\ &= 2 \sin A \sin B \cos(A+B) \geq 0. \quad \square \end{aligned}$$

To prove the theorem, we use induction on  $n$ . The case  $n = 3$  is the classical result mentioned above. Suppose the theorem holds for some  $n \geq 3$  and suppose  $\theta_i \geq 0$  with  $\sum_{i=1}^{n+1} \theta_i = \pi$  and  $\theta_1 \geq \theta_2 \geq \cdots \geq \theta_{n+1}$ . Let  $\phi_i = \theta_i$  for  $i = 1, 2, \dots, n-1$  and  $\phi_n = \theta_n + \theta_{n+1}$ . Then  $\sum_{i=1}^n \phi_i = \pi$  and  $\phi_n \leq \pi/2$ , for otherwise  $\theta_n + \theta_{n+1} > \pi/2$  together with  $n \geq 3$  would imply that  $\sum_{i=1}^{n+1} \theta_i > \pi$ , a contradiction. Hence by the lemma and the induction hypothesis we obtain

$$\sum_{i=1}^{n+1} \sin^2 \theta_i = \sum_{i=1}^{n-1} \sin^2 \phi_i + \sin^2 \theta_n + \sin^2 \theta_{n+1} \leq \sum_{i=1}^n \sin^2 \phi_i \leq \frac{9}{4}.$$

If equality holds it must hold in the lemma. This implies that either  $\theta_{n+1} = 0$  or  $\theta_n + \theta_{n+1} = \pi/2$ . However, if  $\theta_n + \theta_{n+1} = \pi/2$ , then  $\theta_1 + \theta_2 \geq \pi/2$  and since  $\sum_{i=1}^{n+1} \theta_i = \pi$ , we obtain  $\theta_1 + \theta_2 = \pi/2$  and  $n = 4$ . Since  $\theta_1 \geq \theta_2 \geq \theta_3 \geq \theta_4$ , it follows immediately that  $\theta_i = \pi/4$ ,  $i = 1, 2, 3, 4$ , from which we obtain  $\sum_{i=1}^4 \sin^2 \theta_i = 2$ , a contradiction. Thus

$\theta_{n+1} = 0$  which implies  $\phi_i = \theta_i$  for all  $i = 1, 2, \dots, n$ . The induction hypothesis then yields  $\phi_1 = \phi_2 = \phi_3 = \pi/3$  and  $\phi_i = 0$  for  $i = 4, \dots, n$ . On the other hand, the sufficiency of the equality condition is obvious. This completes the proof.

**4.** [1985:304] *Proposed by Canada.*

Prove that

$$\frac{x_1^2}{x_1^2 + x_2x_3} + \frac{x_2^2}{x_2^2 + x_3x_4} + \dots + \frac{x_{n-1}^2}{x_{n-1}^2 + x_nx_1} + \frac{x_n^2}{x_n^2 + x_1x_2} \leq n - 1,$$

where all  $x_i > 0$ .

*Solution by Edward T.H. Wang, Wilfrid Laurier University, Waterloo, Ontario.*

Let  $S_n$  denote the cyclic sum. Clearly

$$S_2 = \frac{x_1^2}{x_1^2 + x_2x_1} + \frac{x_2^2}{x_2^2 + x_1x_2} = 1.$$

We prove by induction that  $S_n < n - 1$  for all  $n \geq 3$ . Consider the case  $n = 3$ . Since the sum is cyclic and since the expression is unchanged when  $x_2$  and  $x_3$  are interchanged, we may assume that  $x_1 \leq x_2 \leq x_3$ . Then

$$S_3 = \frac{x_1^2}{x_1^2 + x_2x_3} + \frac{x_2^2}{x_2^2 + x_3x_1} + \frac{x_3^2}{x_3^2 + x_1x_2} < \frac{x_1^2}{x_1^2 + x_2x_1} + \frac{x_2^2}{x_2^2 + x_2x_1} + 1 = 2.$$

Now suppose  $S_n < n - 1$  for some  $n \geq 3$  and consider  $S_{n+1}$  for  $n + 1$  positive numbers  $x_1, x_2, \dots, x_{n+1}$ . Without loss of generality, we may assume that  $x_{n+1} = \max\{x_i : i = 1, 2, \dots, n + 1\}$ . Note that

$$S_{n+1} = S_n + \frac{x_{n-1}^2}{x_{n-1}^2 + x_nx_{n+1}} + \frac{x_n^2}{x_n^2 + x_{n+1}x_1} + \frac{x_{n+1}^2}{x_{n+1}^2 + x_1x_2} - \frac{x_{n-1}^2}{x_{n-1}^2 + x_nx_1} - \frac{x_n^2}{x_n^2 + x_1x_2}.$$

Since

$$\frac{x_{n-1}^2}{x_{n-1}^2 + x_nx_{n+1}} \leq \frac{x_{n-1}^2}{x_{n-1}^2 + x_nx_1}, \quad \frac{x_n^2}{x_n^2 + x_{n+1}x_1} \leq \frac{x_n^2}{x_n^2 + x_1x_2}, \quad \text{and} \quad \frac{x_{n+1}^2}{x_{n+1}^2 + x_1x_2} < 1,$$

we conclude that  $S_{n+1} < S_n + 1 < n$ , completing the induction.

*Remark.* If we set  $x_i = t^i$  for  $i = 1, 2, \dots, n - 1$ , and  $x_n = t^{2n}$ , then

$$S_n = \frac{t^2}{t^2 + t^5} + \frac{t^4}{t^4 + t^7} + \dots + \frac{t^{2n-4}}{t^{2n-4} + t^{3n-1}} + \frac{t^{2n-2}}{t^{2n-2} + t^{2n+1}} + \frac{t^{4n}}{t^{4n} + t^3} \\ \longrightarrow n - 1 \quad \text{as } t \longrightarrow 0^+.$$

That is, though the bound  $n - 1$  can not be attained for  $n > 2$ , it is nonetheless *sharp*.

\*                     \*                     \*

This completes the “archive” material for 1985 and the space available this number. Contest season is upon us. Send me your contests and solutions!

## BOOK REVIEW

*30th International Mathematical Olympiad, Braunschweig, 1989 - Problems and Results*, edited by Hanns-Heinrich Langmann. K.H. Bock, 5340 Bad Honnef, Germany, 1990. ISBN 3-87066-213-1. 79 pp., softcover. *Reviewed by Richard Nowakowski, Dalhousie University.*

This report on the 1989 IMO first lists the rules and regulations governing the competition. The program of events comes next followed by the competition problems and solutions. All 109 proposed problems are listed next with solutions given to the 32 that were shortlisted by the jury. (These 32 problems have appeared in *CruX* in [1989: 196–197, 225–226, 260–262].) The contestants' scores and awards are given last. The book is an excellent source of problems, but it would have been nice to see the solutions given to more of the difficult problems which were not shortlisted. For example, I have yet to see a good proof (one reasonably explained and under four pages long) of the following proposed question:

HEL 2. In a triangle  $ABC$  for which  $6(a+b+c)r^2 = abc$  holds and where  $r$  denotes the inradius of  $ABC$ , we consider a point  $M$  of its inscribed circle and projections  $D, E, F$  of  $M$  on the sides  $BC, AC, AB$ , respectively. Let  $S$  and  $S_1$  denote the areas of the triangles  $ABC$  and  $DEF$ , respectively. Find the maximum and minimum values of the quotient  $S/S_1$ .

\*                    \*                    \*                    \*                    \*

## CALL FOR PAPERS – ICME

There will be two 90-minute sessions at the ICME in Quebec City (August 1992) on **mathematical competitions**. Papers are solicited on this topic which are of general interest to the mathematics education community.

Enquiries and proposals for papers should be sent to

Dr. E.J. Barbeau  
Department of Mathematics  
University of Toronto  
Toronto, Ontario M5S 1A1  
Canada

email: barbeau@math.toronto.edu  
fax: (416)978-4107  
phone: (416)978-7200

Please send notice of your desire to present a paper no later than **May 31, 1991**.

## PROBLEMS

*Problem proposals and solutions should be sent to B. Sands, Department of Mathematics and Statistics, University of Calgary, Calgary, Alberta, Canada T2N 1N4. Proposals should, whenever possible, be accompanied by a solution, references, and other insights which are likely to be of help to the editor. An asterisk (\*) after a number indicates a problem submitted without a solution.*

*Original problems are particularly sought. But other interesting problems may also be acceptable provided they are not too well known and references are given as to their provenance. Ordinarily, if the originator of a problem can be located, it should not be submitted by somebody else without permission.*

*To facilitate their consideration, your solutions, typewritten or neatly handwritten on signed, separate sheets, should preferably be mailed to the editor before **September 1, 1991**, although solutions received after that date will also be considered until the time when a solution is published.*

**1611.** *Proposed by George Tsintsifas, Thessaloniki, Greece.*

Let  $ABC$  be a triangle with angles  $A, B, C$  (measured in radians), sides  $a, b, c$ , and semiperimeter  $s$ . Prove that

$$(i) \sum \frac{b+c-a}{A} \geq \frac{6s}{\pi}; \quad (ii) \sum \frac{b+c-a}{aA} \geq \frac{9}{\pi}.$$

**1612\***. *Proposed by Walther Janous, Ursulinengymnasium, Innsbruck, Austria.*

Let  $x, y, z$  be positive real numbers. Show that

$$\sum \frac{y^2 - x^2}{z + x} \geq 0,$$

where the sum is cyclic over  $x, y, z$ , and determine when equality holds.

**1613.** *Proposed by Murray S. Klamkin, University of Alberta.*

Prove that

$$\left(\frac{\sin x}{x}\right)^{2p} + \left(\frac{\tan x}{x}\right)^p \geq 2$$

for  $p \geq 0$  and  $0 < x < \pi/2$ . (The case  $p = 1$  is problem E3306, *American Math. Monthly*, solution in March 1991, pp. 264–267.)

**1614.** *Proposed by Toshio Seimiya, Kawasaki, Japan.*

Let  $D$  and  $E$  be points on side  $BC$  of a triangle  $ABC$ . Draw lines through  $D, E$  parallel to  $AC, AB$  respectively, meeting  $AB$  and  $AC$  at  $F$  and  $G$ . Let  $P$  and  $Q$  be the intersections of line  $FG$  with the circumcircle of  $\triangle ABC$ . Prove that  $D, E, P$  and  $Q$  are concyclic.

**1615.** Proposed by Clark Kimberling, University of Evansville, Evansville, Indiana.

Consider the following array:

1	2	3	4	5	6	7	8	9	10	...
2	3	4	5	6	7	8	9	10	11	...
4	2	5	6	7	8	9	10	11	12	...
6	2	7	4	8	9	10	11	12	13	...
8	7	9	2	10	6	11	12	13	14	...
6	2	11	9	12	7	13	8	14	15	...
⋮	⋮	⋮	⋮	⋮	⋮	⋮	⋮	⋮	⋮	⋮

For example, to produce row 5 from row 4, write down, in order: the 1st number to the right of 4, the 1st number to the left of 4, the 2nd to the right of 4, the 2nd to the left of 4, the 3rd to the right of 4, the 3rd to the left of 4, and then the 4th, 5th, ... numbers to the right of 4.

Notice that a number will be expelled from a row if and only if it is the diagonal element in the previous row (the boxed numbers in the array), and once missing it of course never reappears.

- (a) Is 2 eventually expelled?  
 (b)\* Is every positive integer eventually expelled?

**1616.** Proposed by D.J. Smeenk, Zaltbommel, The Netherlands.

In triangle  $ABC$ , angles  $\alpha$  and  $\gamma$  are acute,  $D$  lies on  $AC$  so that  $BD \perp AC$ , and  $E$  and  $F$  lie on  $BC$  so that  $AE$  and  $AF$  are the interior and exterior bisectors of  $\angle BAC$ . Suppose that  $BC$  is the exterior bisector of  $\angle ABD$ . Show that  $AE = AF$ .

**1617.** Proposed by Stanley Rabinowitz, Westford, Massachusetts.

If  $p$  is a prime and  $a$  and  $k$  are positive integers such that  $p^k | (a - 1)$ , then prove that

$$p^{n+k} | (a^{p^n} - 1)$$

for all positive integers  $n$ .

**1618.** Proposed by Jordan Tabov, Sofia, Bulgaria. (Dedicated to Dan Pedoe on the occasion of his 80th birthday.)

The sides of a given angle  $\alpha$  intersect a given circle  $O(r)$  in four points. Four circles  $O_k(r_k)$ ,  $k = 1, 2, 3, 4$ , are inscribed in  $\alpha$  so that  $O_1(r_1)$  and  $O_4(r_4)$  touch  $O(r)$  externally, and  $O_2(r_2)$  and  $O_3(r_3)$  touch  $O(r)$  internally. Prove that  $r_1 r_4 = r_2 r_3$ . (This is more general than problem 1.8.9, page 20, of *Japanese Temple Geometry Problems* by H. Fukagawa and D. Pedoe.)

**1619.** Proposed by Hui-Hua Wan and Ji Chen, Ningbo University, Zhejiang, China.

Let  $P$  be an interior point of a triangle  $ABC$  and let  $R_1, R_2, R_3$  be the distances from  $P$  to the vertices  $A, B, C$ , respectively. Prove that, for  $0 < k < 1$ ,

$$R_1^k + R_2^k + R_3^k < (1 + 2^{\frac{1}{k-1}})^{1-k} (a^k + b^k + c^k).$$

**1620.** *Proposed by Ilia Blaskov, Technical University, Gabrovo, Bulgaria.*

Find a finite set  $S$  of (at least two) points in the plane such that the perpendicular bisector of the segment joining any two points in  $S$  passes through exactly two points of  $S$ .

\*                      \*                      \*                      \*                      \*

## SOLUTIONS

*No problem is ever permanently closed. The editor will always be pleased to consider for publication new solutions or new insights on past problems.*

**1390.** [1988: 269; 1990: 27] *Proposed by H. Fukagawa, Aichi, Japan.*

$A, B, C$  are points on a circle, such that  $CM$  is the perpendicular bisector of  $AB$  [where  $M$  lies on  $AB$ ].  $P$  is a point on  $CM$  and  $AP$  meets the circle again at  $D$ . As  $P$  varies over segment  $CM$ , find the largest radius of the inscribed circle tangent to segments  $PD$ ,  $PB$ , and arc  $DB$  of the circle, in terms of the length of  $CM$ .

II. *Solution by D.J. Smeenk, Zaltbommel, The Netherlands.*

Let  $(O, R)$  be the circumcircle of  $\triangle ABC$ , and  $(Q, \rho)$  the given inscribed circle. We denote

$$\varphi = \angle PAB = \angle PBA = \angle BPQ = \angle SPQ,$$

$S$  being the projection of  $Q$  to  $PD$ . Let  $MA = MB = x$ ,  $OM = d$ ,  $PM = m$ .  $C'$  is the second intersection point of  $CP$  and the circle.

In right triangle  $OPQ$  we have

$$PQ = \frac{\rho}{\sin \varphi}, \quad OP = m - d, \quad OQ = R - \rho$$

and so

$$\frac{\rho^2}{\sin^2 \varphi} + (m - d)^2 = (R - \rho)^2,$$

or

$$\rho^2 \cot^2 \varphi + 2R\rho - R^2 + (m - d)^2 = 0. \quad (1)$$

Now

$$\cot^2 \varphi = \frac{x^2}{m^2} = \frac{R^2 - d^2}{m^2},$$

and (1) becomes

$$\rho^2(R^2 - d^2) + 2Rm^2\rho - m^2[R^2 - (m - d)^2] = 0. \quad (2)$$

It is clear that  $R > m - d$ , so  $R^2 - (m - d)^2 > 0$ , and we conclude that (2) has two different roots  $\rho_1 > 0$  and  $\rho_2 < 0$ .  $D$  being the discriminant of (2) we have

$$\begin{aligned}\frac{D}{4} &= R^2m^4 + m^2(R^2 - d^2)[R^2 - (m - d)^2] \\ &= m^2(R^4 - 2R^2d^2 + d^4 + 2R^2dm - 2d^3m + d^2m) \\ &= m^2(R^2 - d^2 + dm)^2.\end{aligned}$$

So

$$\begin{aligned}\rho_1 &= \frac{-Rm^2 + m(R^2 - d^2 + dm)}{R^2 - d^2} \\ &= \frac{m(R^2 - d^2) - m^2(R - d)}{R^2 - d^2} \\ &= \frac{m(R + d) - m^2}{R + d} = \frac{m(R + d - m)}{R + d},\end{aligned}$$

and thus

$$\frac{1}{\rho_1} = \frac{R + d}{m(R + d - m)} = \frac{1}{m} + \frac{1}{R + d - m} = \frac{1}{PM} + \frac{1}{PC}, \quad (3)$$

the ‘‘harmonic mean’’ property given on [1990: 27], with a maximum for  $\rho_1$  when  $PM = PC$ . Also

$$\begin{aligned}\rho_2 &= \frac{-Rm^2 - m(R^2 - d^2 + dm)}{R^2 - d^2} \\ &= \frac{-m(R^2 - d^2) - m^2(R + d)}{R^2 - d^2} \\ &= \frac{-m(R - d) - m^2}{R - d} = \frac{-m(R - d + m)}{R - d},\end{aligned}$$

so

$$\frac{1}{\rho_2} = \frac{1}{R - d + m} - \frac{1}{m} = \frac{1}{PC'} - \frac{1}{PM}. \quad (4)$$

From (3) and (4) follows

$$\frac{1}{\rho_1} + \frac{1}{\rho_2} = \frac{1}{PC'} + \frac{1}{PC}.$$

$\rho_2$  has a geometrical meaning:  $-\rho_2 > 0$  is the radius of the circle touching the productions of  $AP$  and  $PB$ , and touching, externally. In the figure,  $(Q', \rho')$  is this circle. We have

$$\frac{\rho'^2}{\sin^2 \varphi} + (m - d)^2 = (R + \rho')^2$$

or (as above)

$$\rho'^2(R^2 - d^2) - 2Rm^2\rho' - m^2[R^2 - (m - d)^2] = 0. \quad (5)$$

Comparing (2) and (5) we conclude: if (2) has the roots  $\rho_1$  and  $\rho_2$ , then (5) has the roots  $-\rho_1$  and  $-\rho_2$ .

III. *Solution by Albert W. Walker, Toronto, Ontario.*

We use the following result, due to Poncelet (e.g., [2]):

THEOREM. *Let points  $A, B, C, D$  lie on one circle  $O$  of a coaxial family of circles, and suppose that a second circle  $I$  of the family touches lines  $AB$  and  $CD$ . Then there are circles  $J$  and  $K$  of the family,  $J$  touching  $AC$  and  $BD$ , and  $K$  touching  $AD$  and  $BC$ . Moreover the six contact points of  $I, J, K$  with these lines are collinear.  $\square$*

[*Editor's note:* expert colleague Chris Fisher, University of Regina, also suggests the reference [1].]

In the present problem we draw the parallel to  $AB$  through  $D$ , letting it meet  $CM$  at  $M'$  and , again at  $D'$ , and let  $\mathcal{I}$  (with centre  $I$ ) be the circle tangent to these parallels and internally tangent to , at a point  $L$  in the minor arc  $BD$ . The coaxial family containing , and  $\mathcal{I}$  is thus the family of all circles mutually tangent at  $L$ . By the above theorem of Poncelet, the incircle  $(Q, \rho)$  tangent to  $AD, BD'$ , and minor arc  $BD$  of , will be tangent to , at  $L$ . A fourth circle, exterior to , , will be tangent to , at  $L$  and also to  $AD'$  and  $BD$ .

Let  $E$  be the midpoint of  $AD$ , so that  $OE \perp AD$  and  $EI \perp MM'$ , and  $EI$  meets  $MM'$  at its midpoint  $N$ . Let  $CC'$  be a diameter of , . Put  $AP = a, CP = c, MP = m$ . Then  $C'M + m = C'P = R + OP$ , or

$$C'M - OP = R - m. \quad (1)$$

We have

$$(AM)^2 = CM \cdot C'M \quad (2)$$

so that

$$\frac{ON}{OP} = \frac{ON}{OE} \cdot \frac{OE}{OP} = \left(\frac{AM}{AP}\right)^2 = \frac{CM \cdot C'M}{a^2}, \quad (3)$$

or

$$a^2 ON = OP \cdot CM \cdot C'M. \quad (4)$$

Also

$$\frac{ON}{OP} = \frac{OI}{OQ} = \frac{R - IL}{R - QL} = \frac{R - MN}{R - \rho},$$

and thus from (3),

$$\frac{R - MN}{R - \rho} = \frac{CM \cdot C'M}{a^2}. \quad (5)$$

Next  $R + ON = C'N = C'M + MN$ , and so

$$R - MN = C'M - ON. \quad (6)$$

Now we have from (5),(6),(4),(2) and (1),

$$\begin{aligned} CM \cdot C'M \cdot (R - \rho) &= a^2(R - MN) = a^2(C'M - ON) \\ &= C'M(a^2 - OP \cdot CM) = C'M(m^2 + (AM)^2 - OP \cdot CM) \\ &= C'M(m^2 + CM(C'M - OP)) = C'M(R \cdot CM - (CM - m)m) \\ &= C'M(R \cdot CM - cm). \end{aligned}$$

Thus  $CM(R - \rho) = R \cdot CM - cm$ , or

$$\rho = \frac{cm}{CM} = \frac{cm}{c + m}.$$

Therefore the diameter  $2\rho$  of the incircle is the harmonic mean of  $CP$  and  $MP$  (and, incidentally, also of  $C'P$  and  $M'P$ ). The result then follows as before.

*References:*

- [1] Marcel Berger, *Geometry II* (English translation), Springer, Berlin, 1987, Prop. 16.6.4 and Fig. 16.6.4(2), pp. 203 and 204.  
 [2] H.G. Forder, *Higher Course Geometry*, 1931/49, p. 224.

*Editor's note.* Walker also observes that, letting  $CQ$  and  $AMB$  meet at  $S$ , and  $CL$  and  $PQ$  meet at  $T$ , one gets  $MS = PT = PA$ , and therefore  $OL, CS, PT$  concur (at  $Q$ ). He uses this approach to give a second solution, not using the Poncelet theorem.

A further solution has been received from *TOSHIO SEIMIYA*, Kawasaki, Japan. Seimiya first establishes the following lemma. *ABC is a triangle with incenter I and circumcircle,  $\omega_1$ . Let D be a point on side BC. Let  $\omega_2$  be an inscribed circle tangent to the segments AD and DC, at E and F respectively, and to the arc AC of  $\omega_1$ . Then E, F and I are collinear.* Seimiya uses this lemma to prove the present problem, as well as to give another proof of *Cruz* 1260 [1988: 237; 1989: 51]. He also points out that the harmonic mean relationship given above occurs as problem 1.2.7, p. 5 of H. Fukagawa and D. Pedoe, *Japanese Temple Geometry Problems* (reviewed on [1990: 203]).

\* \* \* \* \*

**1430.** [1989: 74; 1990: 158] *Proposed by Mihály Bencze, Brasov, Romania.*

$AD, BE, CF$  are (not necessarily concurrent) cevians in triangle  $ABC$ , intersecting the circumcircle of  $\triangle ABC$  in the points  $P, Q, R$ . Prove that

$$\frac{AD}{DP} + \frac{BE}{EQ} + \frac{CF}{FR} \geq 9.$$

When does equality hold?

II. *Solution by Ji Chen, Ningbo University, China.*

The result may be sharpened to

$$\frac{AD}{DP} + \frac{BE}{EQ} + \frac{CF}{FR} \geq \left(4 - \frac{2r}{R}\right)^2.$$

From the inequality (given in the published solution of Seimiya [1990: 159])

$$\frac{AD}{DP} + \frac{BE}{EQ} + \frac{CF}{FR} \geq \sum \left( \frac{(b+c)^2}{a^2} - 1 \right) = \sum a \cdot \sum \frac{b+c-a}{a^2},$$

where the sums are cyclic over  $a, b, c$ , and the fact that

$$4 - \frac{2r}{R} = 4 - \prod \frac{b+c-a}{a} = \frac{\sum a(b+c-a)^2}{\prod a},$$

it is enough to show that

$$\sum a \cdot \sum b^2 c^2 (b+c-a) \geq \left( \sum a(b+c-a)^2 \right)^2.$$

Putting

$$x = b+c-a, \quad y = c+a-b, \quad z = a+b-c,$$

this becomes

$$\sum x \cdot \sum x \left( \frac{x+y}{2} \right)^2 \left( \frac{x+z}{2} \right)^2 \geq \left( \sum x^2 \left( \frac{y+z}{2} \right) \right)^2,$$

or

$$\sum x \cdot \sum x(x+y)^2(x+z)^2 - 4 \left( \sum x^2(y+z) \right)^2 \geq 0, \quad (1)$$

where the sums are cyclic over  $x, y, z$ . The left side of (1) becomes

$$\begin{aligned} & \sum x^6 + 3 \sum (x^5 y + x^5 z) - \sum (x^4 y^2 + x^4 z^2) - 6 \sum x^3 y^3 \\ & \quad + 2 \sum (x^3 y^2 z + x^3 z^2 y) - 9 \sum x^2 y^2 z^2 \\ & = \left[ \sum x^6 - \sum (x^4 y^2 + x^4 z^2) + 3 \sum x^2 y^2 z^2 \right] + 3 \left[ \sum (x^5 y + x^5 z) - 2 \sum y^3 z^3 \right] \\ & \quad + 2 \left[ \sum (x^3 y^2 z + x^3 z^2 y) - 6 \sum x^2 y^2 z^2 \right] \\ & = \frac{\sum (y^2 + z^2 - x^2)^2 (y^2 - z^2)^2 + 2 \sum y^2 z^2 (y^2 - z^2)^2}{2 \sum x^2} \\ & \quad + 3 \sum yz (y^2 - z^2)^2 + 2 \sum x^2 yz (y - z)^2 \\ & \geq 0, \end{aligned}$$

so (1) follows.

*Editor's note.* Murray Klamkin has obligingly supplied the editor with the following simpler proof of inequality (1). By Cauchy's inequality,

$$\sum x \cdot \sum x(x+y)^2(x+z)^2 \geq \left( \sum x(x+y)(x+z) \right)^2,$$

so it suffices to prove the stronger inequality

$$\sum x(x+y)(x+z) \geq 2 \sum x^2(y+z),$$

which simplifies to

$$\sum x(x-y)(x-z) \geq 0. \quad (2)$$

But assuming without loss of generality that  $x \geq y \geq z$ , (2) follows from

$$x(x-y)(x-z) \geq y(x-y)(y-z) \quad \text{and} \quad z(z-x)(z-y) \geq 0.$$

(2) is the special case  $n = 1$  of Schur's inequality

$$\sum x^n(x-y)(x-z) \geq 0$$

which can be established the same way (see pp. 49–50 of M.S. Klamkin, *International Mathematical Olympiads 1979–1985*, M.A.A., 1986).

\* \* \* \* \*

**1486.** [1989: 269] *Proposed by Jordi Dou, Barcelona, Spain.*

Given three triangles  $T_1, T_2, T_3$  and three points  $P_1, P_2, P_3$ , construct points  $X_1, X_2, X_3$  such that the triangles  $X_2X_3P_1, X_3X_1P_2, X_1X_2P_3$  are directly similar to  $T_1, T_2, T_3$ , respectively.

*Solution by the proposer.*

Denote by  $S_i$  the dilative rotation with centre  $P_i$ , angle  $\gamma_i = \angle A_iC_iB_i$  (in the sense  $C_iA_i$  to  $C_iB_i$ ), and ratio  $r_i = C_iB_i/C_iA_i$ , for  $i = 1, 2, 3$ . For each point  $X$ , the triangle  $XS_i(X)P_i$  will be similar to  $A_iB_iC_i$ . Let  $S = S_1S_2S_3$ , i.e.  $S(X) = S_3(S_2(S_1(X)))$ .  $S$  is a dilative rotation of angle  $\gamma = \gamma_1 + \gamma_2 + \gamma_3$ , ratio  $r = r_1r_2r_3$  and with fixed point  $O$ , say. If we put  $X_2 = O$ ,  $S_1(X_2) = X_3$  and  $S_2(X_3) = X_1$ , then  $S_3(X_1) = S(X_2) = X_2$ . Thus the problem reduces to constructing the fixed point of  $S$  and this point will be  $X_2$ .  $X_3$  and  $X_1$  will then be  $S_1(X_2)$  and  $S_3^{-1}(X_2)$  respectively. If  $\gamma \neq 0^\circ$  or  $360^\circ$ , or  $r \neq 1$ , the problem has a unique solution. [*Editor's note.* Dou ended with a construction of the required points. A construction of the unique fixed point given three noncollinear points and their images under a similarity can be found in references such as Coxeter's *Introduction to Geometry*, page 73.]

\* \* \* \* \*

**1492.** [1989: 297] *Proposed by George Tsintsifas, Thessaloniki, Greece.*

Let  $A'B'C'$  be a triangle inscribed in a triangle  $ABC$ , so that  $A' \in BC, B' \in CA, C' \in AB$ . Suppose also that  $BA' = CB' = AC'$ .

(a) If either the centroids  $G, G'$  or the circumcenters  $O, O'$  of the triangles coincide, prove that  $\triangle ABC$  is equilateral.

(b)\* If either the incenters  $I, I'$  or the orthocenters  $H, H'$  of the triangles coincide, characterize  $\triangle ABC$ .

I. *Solution to part (a) by Murray S. Klamkin, University of Alberta.*

Let  $\mathbf{A}, \mathbf{B}, \mathbf{C}$  denote vectors from a common origin to the respective vertices  $A, B, C$ . It then follows that

$$\mathbf{A}' = \mathbf{B} + \frac{\alpha}{a}(\mathbf{C} - \mathbf{B}) = \frac{\alpha}{a}\mathbf{C} + \left(1 - \frac{\alpha}{a}\right)\mathbf{B}$$

and similarly

$$\mathbf{B}' = \frac{\alpha}{b}\mathbf{A} + \left(1 - \frac{\alpha}{b}\right)\mathbf{C}, \quad \mathbf{C}' = \frac{\alpha}{c}\mathbf{B} + \left(1 - \frac{\alpha}{c}\right)\mathbf{A},$$

where  $a, b, c$  are the respective sides of  $ABC$  and  $\alpha$  is a nonzero constant.

For the case  $G = G'$ , we choose the origin to be the centroid of  $\triangle ABC$  so that  $\mathbf{A} + \mathbf{B} + \mathbf{C} = \mathbf{0}$  and also

$$\mathbf{0} = \mathbf{A}' + \mathbf{B}' + \mathbf{C}' = \left(\frac{\alpha}{b} - \frac{\alpha}{c} + 1\right)\mathbf{A} + \left(\frac{\alpha}{c} - \frac{\alpha}{a} + 1\right)\mathbf{B} + \left(\frac{\alpha}{a} - \frac{\alpha}{b} + 1\right)\mathbf{C}.$$

Thus

$$\mathbf{0} = \left(\frac{1}{b} - \frac{1}{c}\right)\mathbf{A} + \left(\frac{1}{c} - \frac{1}{a}\right)\mathbf{B} + \left(\frac{1}{a} - \frac{1}{b}\right)\mathbf{C} = \left(\frac{2}{b} - \frac{1}{c} - \frac{1}{a}\right)\mathbf{A} + \left(\frac{1}{b} + \frac{1}{c} - \frac{2}{a}\right)\mathbf{B},$$

and so

$$\frac{2}{b} - \frac{1}{c} - \frac{1}{a} = \frac{1}{b} + \frac{1}{c} - \frac{2}{a} = 0,$$

which implies  $a = b = c$ .

For the case  $O = O'$ , we choose the origin to be the circumcenter of  $\triangle ABC$  so that  $|\mathbf{A}| = |\mathbf{B}| = |\mathbf{C}| = R$ , the circumradius. Then also  $|\mathbf{A}'|^2 = |\mathbf{B}'|^2 = |\mathbf{C}'|^2 = R'^2$ , or

$$\begin{aligned} R'^2 &= \frac{\alpha^2}{a^2}|\mathbf{C}|^2 + \left(1 - \frac{\alpha}{a}\right)^2 |\mathbf{B}|^2 + 2 \cdot \frac{\alpha}{a} \left(1 - \frac{\alpha}{a}\right) \mathbf{B} \cdot \mathbf{C} \\ &= \frac{\alpha^2}{a^2}R^2 + \left(1 - \frac{\alpha}{a}\right)^2 R^2 + \frac{2\alpha(a - \alpha)}{a^2}R^2 \cos 2A \\ &= \left(\frac{2\alpha^2}{a^2} - \frac{2\alpha}{a} + 1\right)R^2 + \frac{2\alpha(a - \alpha)}{a^2}R^2 - \frac{4\alpha(a - \alpha)R^2 \sin^2 A}{a^2} \\ &= R^2 - \alpha(a - \alpha), \quad \text{etc.}, \end{aligned}$$

or

$$\alpha(a - \alpha) = R^2 - R'^2 = \alpha(b - \alpha) = \alpha(c - \alpha).$$

Hence  $a = b = c$ .

II. *Solution to part (a) by the proposer.*

It is known (*Cruz* 1464 [1990: 282]) that  $G = G'$  if and only if

$$\frac{BA'}{A'C} = \frac{CB'}{B'A} = \frac{AC'}{C'B};$$

therefore according to our assumption we have  $A'C = B'A = C'B$ , and hence that  $\triangle ABC$  is equilateral.

If  $O = O'$ , we easily find that the triangles  $OA'B$ ,  $OB'C$ ,  $OC'A$  are congruent, so  $\angle OBA' = \angle OCB'$ . But also  $\angle OBA' = \angle OCA'$ , so  $CO$  bisects  $\angle C$ . Similarly we find that  $O = I$ , hence  $\triangle ABC$  is equilateral.

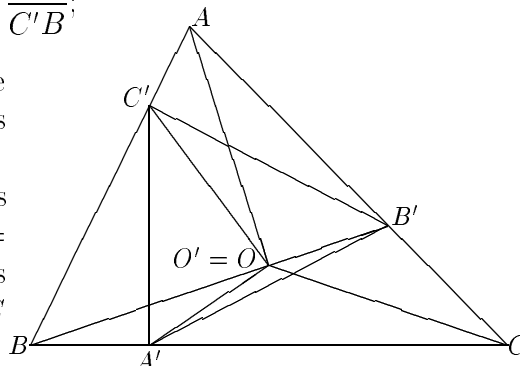

Part (a) also solved by WALTHER JANOUS, Ursulinengymnasium, Innsbruck, Austria; and by D.J. SMEENK, Zaltbommel, The Netherlands.

Part (b) remains unsolved, as did part (c) of the proposer's earlier problem Crux 1464 [1990: 282]; in fact Janous comments that in trying (b) he "got stuck in quite awkward and disgusting expressions", the same predicament that befell him in Crux 1464 ! Looks like these problems need a new idea from someone.

\* \* \* \* \*

**1493.** [1989: 297] Proposed by Toshio Seimiya, Kawasaki, Japan.

Two squares  $ABDE$  and  $ACFG$  are described on  $AB$  and  $AC$  outside the triangle  $ABC$ .  $P$  and  $Q$  are on line  $EG$  such that  $BP$  and  $CQ$  are perpendicular to  $BC$ . Prove that

$$BP + CQ \geq BC + EG.$$

When does equality hold?

I. Solution by Jordi Dou, Barcelona, Spain.

Let  $M, N, O$  be the midpoints of  $BC, PQ, EG$ , respectively. Let  $A'$  be symmetric to  $A$  with respect to  $O$ . We have that  $AE$  is equal and perpendicular to  $BA$ , and analogously  $EA'$  ( $= AG$ ) to  $AC$ . Therefore  $AA' = BC$ ,  $AA' \perp BC$  and  $OE = MA$ ,  $OE \perp MA$ . Let  $L$  on  $MN$  be such that  $AL \parallel OE$ . Then  $AO = LN$ , and  $ML > MA$  because  $MA$  is perpendicular to  $AL$ . Hence  $MN = LN + ML \geq AO + MA$ , and

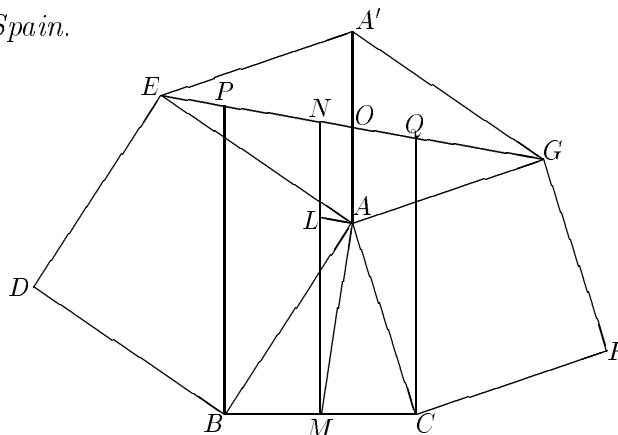

$$BP + CQ = 2MN \geq 2(AO + MA) = 2(BM + OE) = BC + EG.$$

Equality occurs if and only if  $MN = MA + AO$ , i.e.,  $MN$  coincides with  $MO$ , i.e.,  $AB = AC$ .

*Note.* Here is a nice property of triangles between two squares with a common vertex:

The median of one triangle is perpendicular to the base of the other.

The proof is: a rotation of  $90^\circ$  with centre  $O$  moves  $ABFC$  onto  $DGEA$ , consequently  $AM \perp DE$  and  $AN \perp BC$ . This property is a “leitmotif” in the above solution and also in my solution of *Cruix* 1496.

II. *Solution par C. Festraets-Hamoir, Brussels, Belgium.*

Construisons, sur  $BC$  et du même côté que  $A$ , le triangle rectangle isocèle  $BOC$ . La similitude  $\sigma_1$  de centre  $B$ , d'angle  $45^\circ$  et de rapport  $\sqrt{2}/2$  applique  $E$  sur  $A$  et  $O$  sur  $M$ . La similitude  $\sigma_2$  de centre  $C$ , d'angle  $45^\circ$  et de rapport  $\sqrt{2}$  applique  $A$  sur  $G$  et  $M$  sur  $O$ .  $\sigma_2 \circ \sigma_1$  est donc une rotation d'angle  $90^\circ$  (le rapport est  $\sqrt{2} \cdot \sqrt{2}/2 = 1$ ) qui applique  $E$  sur  $G$  et dont le point fixe est  $O$ .  $EOG$  est ainsi un triangle rectangle isocèle.

$M$  étant le milieu de  $BC$ ,

$$BP + CQ = 2MR = 2MO + 2OR = BC + 2OR \geq BC + 2OH = BC + EG.$$

L'égalité a lieu si et seulement si  $OR = OH$ , c'est-à-dire  $EG \parallel BC$ , le triangle  $ABC$  est alors isocèle ( $AB = AC$ ).

*Also solved by FRANCISCO BELLOT ROSADO, I. B. Emilio Ferrari, and MARIA ASCENSIÓN LÓPEZ CHAMORRO, I. B. Leopoldo Cano, Valladolid, Spain; L. J. HUT, Groningen, The Netherlands; WALTHER JANOUS, Ursulinengymnasium, Innsbruck, Austria; MARCIN E. KUCZMA, Warszawa, Poland; KEE-WAI LAU, Hong Kong; and the proposer.*

*The solutions of Kuczma and the proposer were very similar to solution I.*

\* \* \* \* \*

**1494.** [1989: 298] *Proposed by Murray S. Klamkin, University of Alberta.*

Three numbers  $x, y, z$  are chosen independently at random and uniformly in  $[0,1]$ . What is the probability that  $x, y, z$  can be the lengths of the sides of a triangle whose altitudes are also the sides of some triangle?

*Solution by P. Penning, Delft, The Netherlands.*

The probability is equal to the volume in  $x, y, z$ -space where triangles meeting the constraint can be found. Since the size of the triangle cannot play a part, the boundaries of the volume must be straight lines passing through  $(0,0,0)$ .

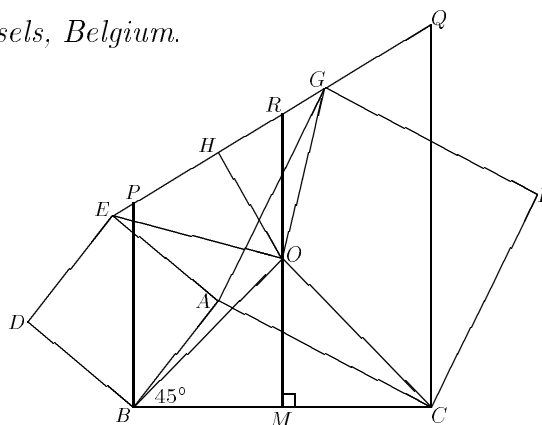

First we impose another constraint,

$$x \leq y \leq z, \quad (1)$$

thereby reducing the relevant volume by a factor of  $3! = 6$ . These numbers form a triangle if

$$x \geq z - y. \quad (2)$$

The altitudes are proportional to  $1/x \geq 1/y \geq 1/z$  (the area of the triangle is the proportionality factor), and they form a triangle if  $1/x \leq 1/y + 1/z$ , i.e.

$$x \geq \frac{yz}{y+z}. \quad (3)$$

The region where conditions (1)–(3) are met is a pyramid, with top at  $(0, 0, 0)$  and base in the plane  $z = 1$ . (The base is shown in the figure.) With integral calculus the area is easily determined to be

$$\ln(\sqrt{5} - 1) + \frac{2 - \sqrt{5}}{4}.$$

The probability is then equal to

$$\begin{aligned} 6(\text{volume of pyramid}) &= 2(\text{area of base}) \\ &= 2 \ln(\sqrt{5} - 1) + 1 - \sqrt{5}/2 \\ &\approx 0.3058. \end{aligned}$$

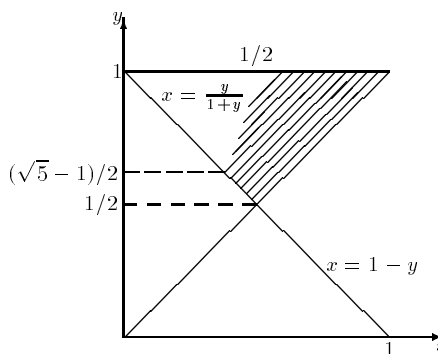

If only the sides have to form a triangle, then the probability is 0.5 .

*Also solved by RICHARD I. HESS, Rancho Palos Verdes, California; MARCIN E. KUCZMA, Warszawa, Poland; and the proposer. A solution similar to Penning's, but with a trivial error at the end, was also sent in by C. FESTAETS-HAMOIR, Brussels, Belgium.*

\* \* \* \* \*

**1495.** [1989: 298] *Proposed by Walther Janous, Ursulinengymnasium, Innsbruck, Austria.*

(a) Show that there exist infinitely many positive integer solutions to

$$c^2 = \binom{a}{2} - \binom{b}{2}.$$

(b)\* If  $k > 2$  is an integer, are there infinitely many solutions in positive integers to

$$c^k = \binom{a}{k} - \binom{b}{k}?$$

I. *Solution to part (a) by Hayo Ahlburg, Benidorm, Spain.*

The equation becomes  $a^2 - a - b^2 + b = 2c^2$  or

$$(a + b - 1)(a - b) = 2c^2.$$

Introducing  $D = a - b$ , we find  $D^2 + (2b - 1)D = 2c^2$ , so

$$b = \frac{c^2}{D} - \frac{D - 1}{2}, \quad a = b + D = \frac{c^2}{D} + \frac{D + 1}{2}.$$

To make  $a$  and  $b$  integers, we have two possibilities.

*Case (i):*  $c^2 = kD$ . Then

$$a = k + \frac{D + 1}{2}, \quad b = k - \frac{D - 1}{2},$$

where  $D$  is odd and  $k$  is any integer which makes  $kD$  a square. For example ( $D = 1$ ):

$$a = c^2 + 1, \quad b = c^2, \quad c \text{ arbitrary.} \quad (1)$$

*Case (ii):*  $c^2 = mD + D/2$ . Here  $D = 2^{2n+1}d$  with  $d$  odd, and  $m$  is any number which makes  $(2m + 1)d$  a square. In this case we have

$$c^2 = (2m + 1)2^{2n}d, \quad a = m + 1 + 2^{2n}d, \quad b = m + 1 - 2^{2n}d.$$

For example ( $D = 2$ ):

$$a = \frac{c^2 + 3}{2}, \quad b = \frac{c^2 - 1}{2}, \quad c \text{ arbitrary odd.} \quad (2)$$

II. *Partial solution to part (b) by Kenneth M. Wilke, Topeka, Kansas.*

[Wilke first solved part (a)—*Ed.*]

Consider  $k = 3$ . Then  $c^3 = \binom{a}{3} - \binom{b}{3}$  becomes

$$\begin{aligned} 6c^3 &= (a - 1)^3 - (a - 1) - [(b - 1)^3 - (b - 1)] \\ &= (a - b)(a^2 + ab + b^2 - 3(a + b) + 2). \end{aligned}$$

Taking  $a = b + 2$ , this becomes  $6c^3 = 2 \cdot 3b^2$ , whence we can take

$$c = t^2, \quad b = t^3, \quad a = t^3 + 2 \quad (t \text{ arbitrary})$$

to produce an infinite number of solutions. These are not all the solutions when  $k = 3$ . Others include  $(a, b, c) = (9, 6, 4)$ ,  $(12, 4, 6)$  and  $(25, 19, 11)$ .

*Also solved (both parts) by H. L. ABBOTT, University of Alberta; HANS ENGELHAUPT, Franz-Ludwig-Gymnasium, Bamberg, Germany; and RICHARD K. GUY,*

University of Calgary. Part (a) only was solved by MATHEW ENGLANDER, Toronto, Ontario; RICHARD A. GIBBS, Fort Lewis College, Durango, Colorado; RICHARD I. HESS, Rancho Palos Verdes, California; FRIEND H. KIERSTEAD JR., Cuyahoga Falls, Ohio; MURRAY S. KLAMKIN, University of Alberta; CHRIS WILDHAGEN, Breda, The Netherlands; and the proposer.

The remarkable solution II was also found by Engelhaupt and by Guy. Abbott's solution to part (b) was a recursively defined infinite sequence of solutions, the first being the trivial

$$1^3 = \binom{3}{3} - \binom{2}{3},$$

and the second being the already formidable

$$16199^3 = \binom{30527}{3} - \binom{14328}{3} !$$

These all have the additional property that  $a = b + c$ . Guy has since found other solutions with this property, for instance

$$26^3 = \binom{50}{3} - \binom{24}{3}.$$

Example (1) of case (i) in Ahlburg's solution was also found by Engelhaupt, Englander and Gibbs, while example (2) of case (ii) was again given by Engelhaupt. Another special case of Ahlburg's case (i), namely  $k = D$  (odd), was found by Hess, Kierstead and Klamkin. This gives the nice solution

$$a = 3b - 1, \quad c = 2b - 1, \quad b \text{ arbitrary.}$$

No solutions for  $k > 3$  were sent in. However, Guy has come up with the single (and singular!) example

$$6^5 = \binom{18}{5} - \binom{12}{5}$$

for  $k = 5$ . Is it part of some infinite family?

\*                    \*                    \*                    \*                    \*

**1496.** [1989: 298] Proposed by H. Fukagawa, Aichi, Japan.

There are four squares  $ABCD$ ,  $DEFG$ ,  $AEIJ$ ,  $BJKL$  as shown in the figure. Show that  $L, C, G$  are collinear if and only if  $2AD = AE$ .

I. *Solution by Jordi Dou, Barcelona, Spain.*

Let  $M, N, O_1$  be the midpoints of  $AE, AJ, CL$ , respectively.  $B'$  is symmetric to  $B$  with respect to  $O_1$ , and  $O$  is the centre of  $ABCD$ .

Triangle  $CBB'$  is obtained from triangle  $BAJ$  by a rotation of  $90^\circ$  about centre  $O$ . Therefore  $BN \perp CL$ . [*Editor's note:* see also Dou's comment at the end of his solution to *Cruix* 1493, this issue!] Analogously,  $DM \perp CG$ . If  $AE = 2AD$  then  $AB = AN = AM = AD$  and  $\angle NAM = \angle BAD (= 90^\circ)$ , so  $BN$  is parallel to  $DM$ , and therefore  $L, C, G$  are collinear. It is clear that if  $AE \neq 2AD$ , then  $DM$  is not parallel to  $BN$  and  $L, C, G$  are not aligned.

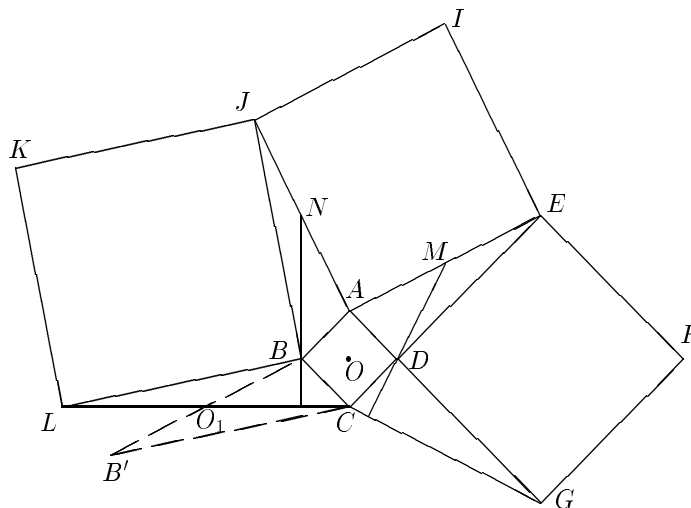

II. *Solution by Marcin E. Kuczma, Warszawa, Poland.*

Consider the vectors  $\vec{AD} = \mathbf{u}$ ,  $\vec{AE} = \mathbf{v}$ . Let  $h$  denote rotation by  $90^\circ$  anticlockwise. Since  $h$  is a linear map,

$$\vec{CL} = \vec{CB} + \vec{BL} = -\mathbf{u} + h(\vec{BJ}) = -\mathbf{u} + h(\vec{AJ}) - h(\vec{AB}) = -\mathbf{u} - \mathbf{v} - \mathbf{u} = -2\mathbf{u} - \mathbf{v}$$

and

$$h(\vec{CG}) = h(\vec{CD}) + h(\vec{DG}) = \vec{DA} + \vec{DE} = -\mathbf{u} - \mathbf{u} + \mathbf{v} = \mathbf{v} - 2\mathbf{u}.$$

Therefore

$$\begin{aligned} L, C, G \text{ are in line} &\iff \vec{CG} \parallel \vec{CL} \iff \vec{CL} \perp h(\vec{CG}) \\ &\iff (2\mathbf{u} + \mathbf{v})(2\mathbf{u} - \mathbf{v}) = 0 \\ &\iff |\mathbf{v}| = 2|\mathbf{u}|. \end{aligned}$$

Also solved by HANS ENGELHAUPT, Franz-Ludwig-Gymnasium, Bamberg, Germany; C. FESTAETS-HAMOIR, Brussels, Belgium; L. J. HUT, Groningen, The Netherlands; WALTHER JANOUS, Ursulinengymnasium, Innsbruck, Austria; MARCIN E. KUCZMA, Warszawa, Poland (a second solution); KEE-WAI LAU, Hong Kong; P. PENNING, Delft, The Netherlands; D.J. SMEENK, Zaltbommel, The Netherlands; and the proposer. One incorrect solution was sent in.

The above solutions are related, but the different approaches are interesting.

The problem was taken from a lost sangaku dated 1826, and appears as problem 4.21, page 47, of Fukagawa and Pedoe's Japanese Temple Geometry Problems. Also given there is the relationship between the sides of the four squares.

\* \* \* \* \*

**1497.** [1989: 298] *Proposed by Ray Killgrove and Robert Sternfeld, Indiana State University, Terre Haute.*

A translate  $g$  of a function  $f$  is a function  $g(x) = f(x + a)$  for some constant  $a$ . Suppose that one translate of a function  $f : \mathbf{R} \rightarrow \mathbf{R}$  is odd and another translate is even. Show that  $f$  is periodic. Is the converse true?

*Solution by the St. Olaf Problem Solving Group, St. Olaf College, Northfield, Minnesota.*

We know that there exist  $a$  and  $b$  such that for every  $x$ ,  $f(x + a) = f(-x + a)$  and  $f(x + b) = -f(-x + b)$ . This implies that  $f(2a + x) = f(-x)$  and  $f(2b + x) = -f(-x)$ . Thus,

$$\begin{aligned} f(x + 4(a - b)) &= f(2a + (x + 2a - 4b)) = f(4b - x - 2a) \\ &= -f(2a + x - 2b) = -f(2b - x) = f(x). \end{aligned}$$

Thus  $f(x)$  has period  $4(a - b)$ . (If  $a = b$ , then  $f(x + a) = f(a - x) = -f(a + x)$  which implies that  $f(x)$  is the zero function.)

The converse is not true. The function  $f(x) = x - [x]$  provides a counterexample.

*Also solved (in about the same way) by SEUNG-JIN BANG, Seoul, Republic of Korea; WALTHER JANOUS, Ursulinengymnasium, Innsbruck, Austria; MURRAY S. KLAMKIN, University of Alberta; MARCIN E. KUCZMA, Warszawa, Poland; DAVID E. MANES, SUNY at Oneonta, New York; CHRIS WILDHAGEN, Breda, The Netherlands; and the proposers.*

\* \* \* \* \*

**1498\***. [1989: 298] *Proposed by D.M. Milošević, Pranjani, Yugoslavia.*

Show that

$$\prod_{i=1}^3 h_i^{a_i} \leq (3r)^{2s},$$

where  $a_1, a_2, a_3$  are the sides of a triangle,  $h_1, h_2, h_3$  its altitudes,  $r$  its inradius, and  $s$  its semiperimeter.

*I. Solution by Mark Kisin, student, Monash University, Clayton, Australia.*

By the generalized A.M.-G.M. inequality,

$$\left( \prod_{i=1}^3 h_i^{a_i} \right)^{1/2s} = \left( \prod_{i=1}^3 h_i^{a_i} \right)^{\frac{1}{a_1+a_2+a_3}} \leq \frac{a_1 h_1 + a_2 h_2 + a_3 h_3}{a_1 + a_2 + a_3}.$$

But

$$a_1 h_1 = a_2 h_2 = a_3 h_3 = 2(\text{Area}) = 2rs,$$

so

$$\left( \prod_{i=1}^3 h_i^{a_i} \right)^{1/2s} \leq \frac{6rs}{2s} = 3r,$$

and the result follows.

II. *Solution by Walther Janous, Ursulinengymnasium, Innsbruck, Austria.*

Using the relations  $h_i = 2F/a_i$  ( $i = 1, 2, 3$ ) and  $r = F/s$ , where  $F$  is the area of the triangle, the stated inequality becomes

$$2^{2s} F^{2s} \prod_{i=1}^3 a_i^{-a_i} \leq 3^{2s} F^{2s} s^{-2s},$$

i.e.

$$\prod_{i=1}^3 a_i^{a_i} \geq \left(\frac{2s}{3}\right)^{2s}. \quad (1)$$

This inequality is the special case  $n = 3$ ,  $p_1 = p_2 = p_3 = 1$ ,  $x_i = a_i$  ( $i = 1, 2, 3$ ) of the following.

THEOREM. Let  $p_1, \dots, p_n$  be positive real numbers and put  $P_n = p_1 + p_2 + \dots + p_n$ . Then for all positive real numbers  $x_1, \dots, x_n$ ,

$$\prod_{i=1}^n x_i^{p_i x_i} \geq \left(\frac{\sum_{i=1}^n p_i x_i}{P_n}\right)^{\sum_{i=1}^n p_i x_i}. \quad (2)$$

*Proof.* The function  $f(x) = x \log x$ ,  $x > 0$ , is convex. Thus we get

$$\sum_{i=1}^n p_i f(x_i) \geq P_n f\left(\frac{\sum_{i=1}^n p_i x_i}{P_n}\right),$$

i.e., (2).  $\square$

Since  $f(x)$  is strictly convex, equality holds in (1) if and only if  $a_1 = a_2 = a_3$ .

[*Editor's note.* Janous also generalizes the problem to  $n$ -dimensional simplices. Using the method of solution I he obtains

$$\prod_{i=1}^{n+1} h_i^{F_i} \leq [(n+1)r]^F,$$

where  $h_i$  are the altitudes,  $F_i$  the  $(n-1)$ -dimensional areas of the faces,  $F = \sum F_i$ , and  $r$  is the inradius.]

*Also solved by L. J. HUT, Groningen, The Netherlands; MURRAY S. KLAMKIN, University of Alberta; and MARCIN E. KUCZMA, Warszawa, Poland.*

*Klamkin's solution was very similar to solution II, obtaining a slightly weaker result.*

\* \* \* \* \*

**1499.** [1989: 298] *Proposed by Herta T. Freitag, Roanoke, Virginia.*

A second-order linear recursive sequence  $\{A_n\}_1^\infty$  is defined by  $A_{n+2} = A_{n+1} + A_n$  for all  $n \geq 1$ , with  $A_1$  and  $A_2$  any integers. Select a set  $S$  of any  $2m$  consecutive elements from this sequence, where  $m$  is an odd integer. Prove that the sum of the numbers in  $S$  is always divisible by the  $(m+2)$ nd element of  $S$ , and the multiplying factor is  $L_m$ , the  $m$ th Lucas number.

*Solution by Chris Wildhagen, Breda, The Netherlands.*

Let

$$\alpha = \frac{1 + \sqrt{5}}{2}, \quad \beta = \frac{1 - \sqrt{5}}{2}.$$

Then  $A_n = r\alpha^n + s\beta^n$  for appropriate constants  $r$  and  $s$ . Thus

$$\begin{aligned} \sum_{k=n}^{n+2m-1} A_k &= \sum_{k=n}^{n+2m-1} (r\alpha^k + s\beta^k) \\ &= r\alpha^n \sum_{k=0}^{2m-1} \alpha^k + s\beta^n \sum_{k=0}^{2m-1} \beta^k \\ &= r\alpha^n \left( \frac{\alpha^{2m} - 1}{\alpha - 1} \right) + s\beta^n \left( \frac{\beta^{2m} - 1}{\beta - 1} \right) \\ &= r\alpha^{n+1}(\alpha^{2m} - 1) + s\beta^{n+1}(\beta^{2m} - 1). \end{aligned} \tag{1}$$

To prove the required result, note that

$$\begin{aligned} A_{n+m+1}L_m &= (r\alpha^{n+m+1} + s\beta^{n+m+1})(\alpha^m + \beta^m) \\ &= r\alpha^{n+2m+1} + r\alpha^{n+1}(\alpha\beta)^m + s\beta^{n+2m+1} + s\beta^{n+1}(\alpha\beta)^m, \end{aligned}$$

and this equals (1), since  $\alpha\beta = -1$ .

*Also solved by RICHARD I. HESS, Rancho Palos Verdes, California; WALTHER JANOUS, Ursulinengymnasium, Innsbruck, Austria; MARCIN E. KUCZMA, Warszawa, Poland; MARIA ASCENSIÓN LÓPEZ CHAMORRO, I.B. Leopoldo Cano, Valladolid, Spain; BOB PRIELIPP, University of Wisconsin-Oshkosh; KENNETH M. WILKE, Topeka, Kansas; and the proposer.*

*López Chamorro points out a related problem, B-31 of the Fibonacci Quarterly, solved on p. 233 of the October 1964 issue.*

\* \* \* \* \*

**1500.** [1989: 299] *Proposed by K.R.S. Sastry, Addis Ababa, Ethiopia.*

A parallelogram is called *self-diagonal* if its sides are proportional to its diagonals. Suppose that  $ABCD$  is a self-diagonal parallelogram in which the bisector of angle  $ADB$  meets  $AB$  at  $E$ . Prove that  $AE = AC - AB$ .

I. *Editor's comment.*

Three readers, MURRAY S. KLAMKIN, University of Alberta, P. PENNING, Delft, The Netherlands, and KENNETH M. WILKE, Topeka, Kansas, point out that this result is **false** in some cases, namely for self-diagonal parallelograms  $ABCD$  satisfying  $AB/BC = BD/AC$ . Here is an example.

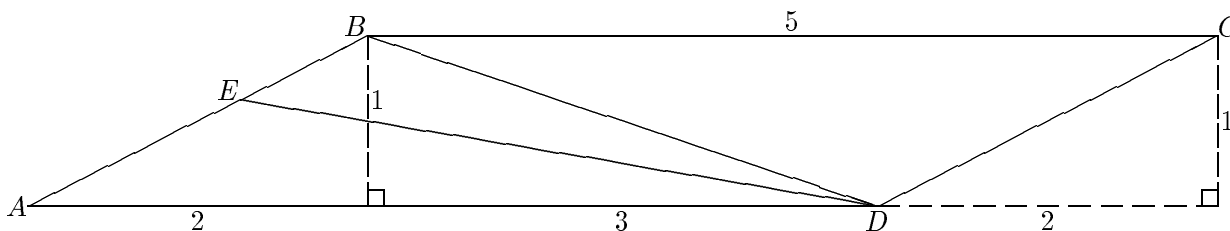

It is easy to see that  $AB = \sqrt{5}$ ,  $AD = 5$ ,  $BD = \sqrt{10}$ , and  $AC = 5\sqrt{2}$ , so  $ABCD$  is self-diagonal. However, it is also pretty obvious that  $AE < AC - AB$ .

Penning and Wilke then showed that the problem is correct in the other case, that  $AB/BC = AC/BD$ , which was the case intended by the proposer and considered by all other solvers. Here are two of these solutions.

II. *Solution by Jack Garfunkel, Flushing, N.Y.*

Denote  $AB = a$ ,  $BC = b$ ,  $AC = d_1$ ,  
 $BD = d_2$ ,  $AE = x$ . We are given

$$\frac{a}{b} = \frac{d_1}{d_2}, \quad (1)$$

and since  $DE$  bisects  $\angle ADB$ ,

$$\frac{x}{a-x} = \frac{b}{d_2},$$

or

$$x = \frac{ab}{b+d_2}.$$

We therefore have to show that

$$\frac{ab}{b+d_2} = d_1 - a,$$

which simplifies (by (1)) to showing that  $2ab = d_1d_2$ . Now it is known that

$$d_1^2 + d_2^2 = 2(a^2 + b^2)$$

or, by (1) again,

$$2(a^2 + b^2) = d_1^2 + \frac{b^2d_1^2}{a^2} = \frac{d_1^2}{a^2}(a^2 + b^2).$$

Hence  $d_1 = a\sqrt{2}$ ,  $d_2 = b\sqrt{2}$ , and so  $d_1d_2 = 2ab$ .

III. *Solution by Toshio Seimiya, Kawasaki, Japan.*

We assume that  $AB : AD = AC : BD$ ,  
whence we get

$$AB \cdot BD = AD \cdot AC. \quad (2)$$

We put  $\angle ABD = \alpha$ ,  $\angle DAC = \beta$ . Because  $ABCD$  is a parallelogram,

$$\text{area } \triangle ABD = \text{area } \triangle ACD.$$

Therefore we get

$$\frac{1}{2}AB \cdot BD \sin \alpha = \frac{1}{2}AD \cdot AC \sin \beta.$$

Hence from (2) we have  $\sin \alpha = \sin \beta$ , and since  $\alpha + \beta < \pi$  we get  $\alpha = \beta$ . Let  $F$  be the point of intersection of  $AC$  with  $DE$ . As

$$\angle AEF = \alpha + \angle EDB = \beta + \angle ADE = \angle AFE,$$

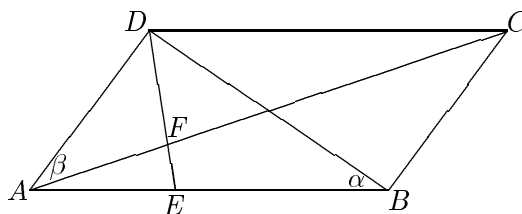
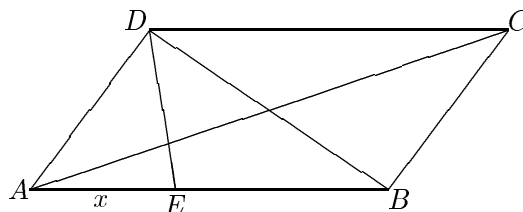

we get  $AE = AF$ . Because

$$\angle CDF = \angle AEF = \angle AFE = \angle CFD,$$

we have  $CF = CD$ . Hence

$$AE = AF = AC - CF = AC - CD = AC - AB.$$

Also solved by WILSON DA COSTA AREIAS, Rio de Janeiro, Brazil; FRANCISCO BELLOT ROSADO, I.B. Emilio Ferrari, Valladolid, Spain; JORDI DOU, Barcelona, Spain; HANS ENGELHAUPT, Franz-Ludwig-Gymnasium, Bamberg, Germany; RICHARD A. GIBBS, Fort Lewis College, Durango, Colorado; RICHARD I. HESS, Rancho Palos Verdes, California; L.J. HUT, Groningen, The Netherlands; WALTHER JANOUS, Ursulinengymnasium, Innsbruck, Austria; ANTONIO LUIZ SANTOS, Rio de Janeiro, Brazil; D.J. SMEENK, Zaltbommel, The Netherlands; and the proposer.

\* \* \* \* \*

**1501.** [1990: 19] Proposed by J.T. Groenman, Arnhem, The Netherlands.

Two circles  $K$  and  $K_1$  touch each other externally. The equilateral triangle  $ABC$  is inscribed in  $K$ , and points  $A_1, B_1, C_1$  lie on  $K_1$  such that  $AA_1, BB_1, CC_1$  are tangent to  $K_1$ . Prove that one of the lengths  $\overline{AA_1}, \overline{BB_1}, \overline{CC_1}$  equals the sum of the other two. (The case when the circles are internally tangent was a problem of Florow in *Praxis der Mathematik* 13, Heft 12, page 327.)

*Solution by Marcin E. Kuczma, Warszawa, Poland.*

Let  $O, O_1, r, r_1$  be the centers and radii of  $K$  and  $K_1$ , and let  $T$  be the point of tangency. Assume without loss of generality that  $T$  belongs to the shorter arc  $AB$ . Then by Ptolemaeus,  $\overline{AT} \cdot \overline{BC} + \overline{BT} \cdot \overline{CA} = \overline{CT} \cdot \overline{AB}$ , whence

$$\overline{AT} + \overline{BT} = \overline{CT}. \tag{1}$$

[This is of course known. —Ed.] Produce  $AT$  to cut  $K_1$  again in  $D$ . The isosceles triangles  $AOT$  and  $TO_1D$  are similar in ratio  $r : r_1$ , and so  $\overline{AD}/\overline{AT} = (r + r_1)/r$ . Thus

$$\overline{AA_1} = \sqrt{\overline{AT} \cdot \overline{AD}} = \sqrt{\frac{r + r_1}{r}} \cdot \overline{AT},$$

and similarly for  $\overline{BB_1}$  and  $\overline{CC_1}$ . The claim results by (1).

Also solved by WILSON DA COSTA AREIAS, Rio de Janeiro, Brazil; FRANCISCO BELLOT ROSADO, I.B. Emilio Ferrari, Valladolid, Spain; JORDI DOU, Barcelona, Spain; HANS ENGELHAUPT, Franz-Ludwig-Gymnasium, Bamberg, Germany; C. FESTAETS-HAMOIR, Brussels, Belgium; RICHARD A. GIBBS, Fort Lewis College, Durango, Colorado; JEFF HIGHAM, student, University of Toronto; L. J. HUT, Groningen, The Netherlands; WALTHER JANOUS, Ursulinengymnasium, Innsbruck, Austria;

DAG JONSSON, Uppsala, Sweden; TOSHIO SEIMIYA, Kawasaki, Japan; D.J. SMEENK, Zaltbommel, The Netherlands; HUME SMITH, Chester, Nova Scotia; and the proposer. Several solvers gave the above solution.

Janous located the problem in two Bulgarian sources: problem 38, page 58 of Davidov, Petkov, Tonov, and Chukanov, *Mathematical Contests, Sofia, 1977*; and problem 4.32, pages 55–56 of J. Tabov, *Homothety in Problems, Sofia, 1989*. He also found similar problems on pp. 172–175 of Honsberger's *Mathematical Morsels, MAA, 1978*.

\* \* \* \* \*

**1503.** [1990: 19] *Proposed by M.S. Klamkin, University of Alberta.*

Prove that

$$1 + 2 \cos(B + C) \cos(C + A) \cos(A + B) \geq \cos^2(B + C) + \cos^2(C + A) + \cos^2(A + B),$$

where  $A, B, C$  are nonnegative and  $A + B + C \leq \pi$ .

*I. Solution by C. Festraets-Hamoir, Brussels, Belgium.*

Put

$$B + C = \alpha, \quad C + A = \beta, \quad A + B = \gamma;$$

then the proposed inequality is  $T \leq 0$  where

$$T = \cos^2 \alpha + \cos^2 \beta + \cos^2 \gamma - 2 \cos \alpha \cos \beta \cos \gamma - 1.$$

Solving  $T = 0$  by considering  $T$  as a quadratic in  $\cos \alpha$ , we obtain

$$\begin{aligned} \cos \alpha &= \frac{2 \cos \beta \cos \gamma \pm \sqrt{4 \cos^2 \beta \cos^2 \gamma - 4(\cos^2 \beta + \cos^2 \gamma - 1)}}{2} \\ &= \cos \beta \cos \gamma \pm \sqrt{(1 - \cos^2 \beta)(1 - \cos^2 \gamma)} \\ &= \cos \beta \cos \gamma \pm \sin \beta \sin \gamma = \cos(\beta \mp \gamma). \end{aligned}$$

Thus

$$\begin{aligned} T &= (\cos \alpha - \cos(\beta + \gamma))(\cos \alpha - \cos(\beta - \gamma)) \\ &= 4 \sin \frac{\alpha + \beta + \gamma}{2} \sin \frac{\alpha - \beta - \gamma}{2} \sin \frac{\alpha + \beta - \gamma}{2} \sin \frac{\alpha - \beta + \gamma}{2} \\ &= 4 \sin(A + B + C) \sin(-A) \sin C \sin B \\ &= -4 \sin(A + B + C) \sin A \sin B \sin C \\ &\leq 0, \end{aligned}$$

since  $A + B + C \leq \pi$  and  $A, B, C$  are non-negative.

II. *Solution by the proposer.*

Let

$$x = B + C, \quad y = C + A, \quad z = A + B.$$

Then  $x + y + z \leq 2\pi$ . Since  $2A = y + z - x$ , etc.,  $x, y, z$  must satisfy the triangle inequality. Hence  $x, y, z$  are the angles of a (possibly degenerate) trihedral angle. If  $\mathbf{P}, \mathbf{Q}, \mathbf{R}$  denote unit vectors along the edges of this trihedral angle from the vertex, the volume  $V$  of the tetrahedron formed from  $\mathbf{P}, \mathbf{Q}, \mathbf{R}$  is given by  $6V = \mathbf{P} \cdot (\mathbf{Q} \times \mathbf{R})$  [p. 26 problem 37 of Spiegel, *Vector Analysis* (Schaum)]. Squaring, we obtain [p. 33 problem 89 of the same reference]

$$36V^2 = \begin{vmatrix} \mathbf{P} \cdot \mathbf{P} & \mathbf{P} \cdot \mathbf{Q} & \mathbf{P} \cdot \mathbf{R} \\ \mathbf{Q} \cdot \mathbf{P} & \mathbf{Q} \cdot \mathbf{Q} & \mathbf{Q} \cdot \mathbf{R} \\ \mathbf{R} \cdot \mathbf{P} & \mathbf{R} \cdot \mathbf{Q} & \mathbf{R} \cdot \mathbf{R} \end{vmatrix} = \begin{vmatrix} 1 & \cos y & \cos z \\ \cos y & 1 & \cos x \\ \cos z & \cos x & 1 \end{vmatrix}.$$

On expanding out the determinant, we see that the given inequality corresponds to  $V^2 \geq 0$ . There is equality if and only if  $x + y + z = 2\pi$  or one of  $x, y, z$  equals the sum of the other two; correspondingly, if and only if  $A + B + C = \pi$  or  $ABC = 0$ .

*Also solved by SEUNG-JIN BANG, Seoul, Republic of Korea; WALTHER JANOUS, Ursulinengymnasium, Innsbruck, Austria; MARCIN E. KUCZMA, Warszawa, Poland; and KEE-WAI LAU, Hong Kong.*

\*                     \*                     \*                     \*                     \*

## JACK GARFUNKEL

One of *CruX*'s regular contributors since its earliest days, Jack Garfunkel, passed away on New Year's Eve, 1990. His many proposals in geometry, sometimes very difficult, but often beautiful, were well appreciated by *CruX* readers. He will be missed. The following information on his life was kindly furnished by his son, Sol Garfunkel.

Jack was born in Poland in 1910 and came to the United States at the age of nine. Although one of the top math majors at City College in New York, he left academic life after graduation to help his family weather the depression. For the next 25 years, he worked manufacturing candy. At the age of 45, he returned to his first love and became a high school mathematics teacher. Over the next 24 years, he taught at Forest Hills High School, supervising over two dozen Westinghouse finalist and semi-finalist winners of the talent search. When he "retired" from high school teaching, he immediately began work as an adjunct professor at Queens College and later at Queensborough Community College, where he taught until November of 1990.

Throughout his two careers as candyman and teacher, he continued to *do* mathematics, conjecturing and solving problems in synthetic geometry and geometric inequalities. While his formal education ended with his undergraduate work, he never lost his curiosity and love of his subject.